

Dual presents the 701.

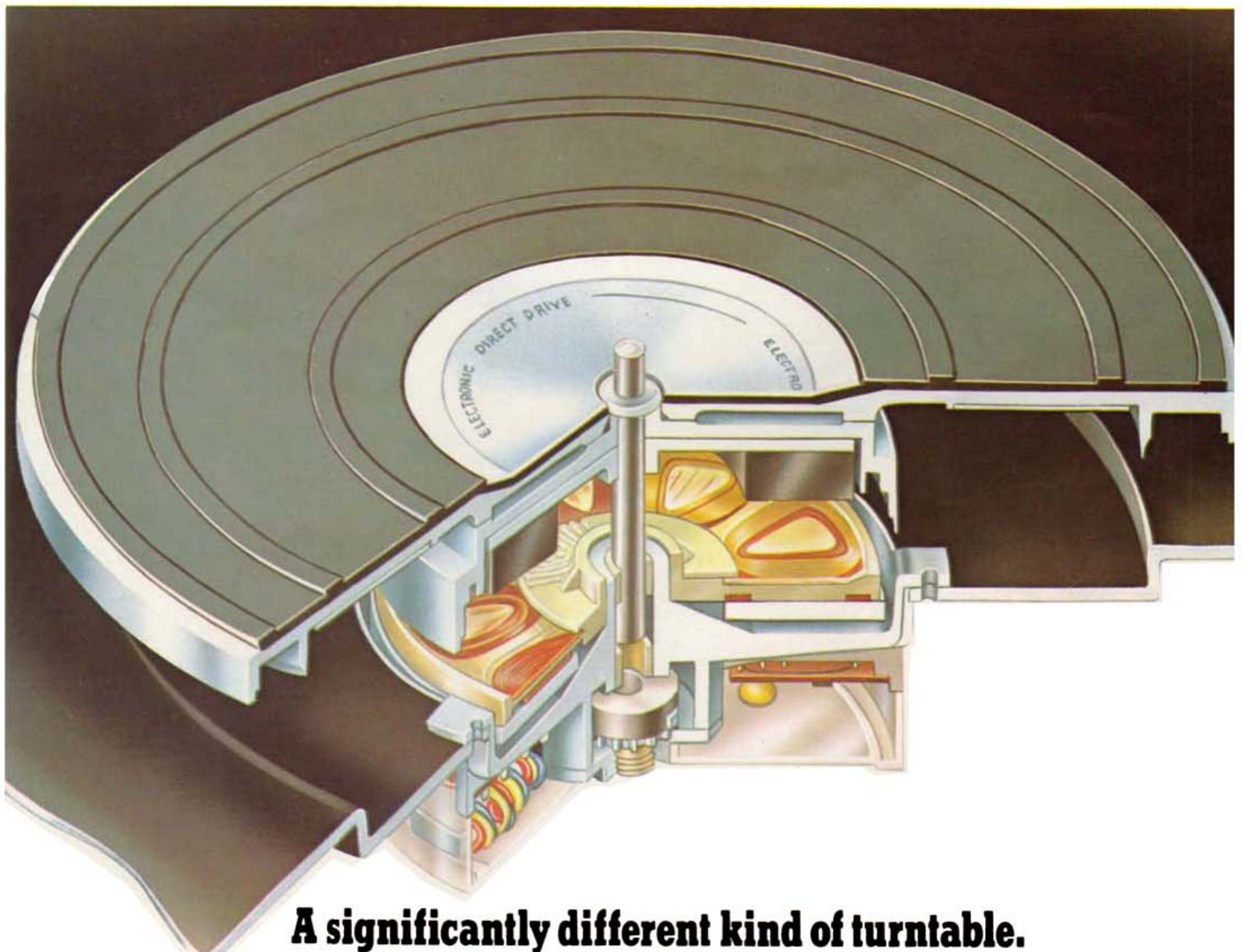

A significantly different kind of turntable.

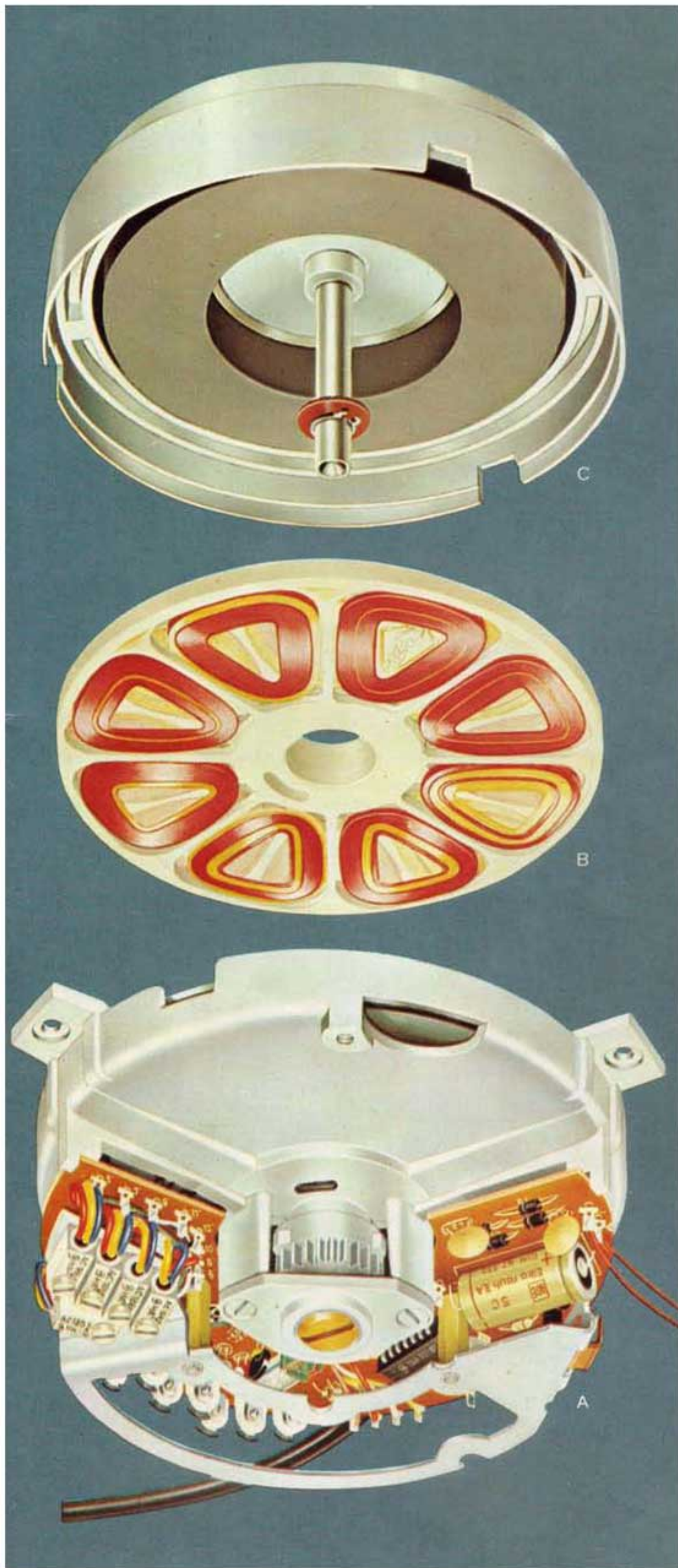

Electronically-regulated, direct-drive motor with exclusive overlapping coil system.

The bottom element (A) houses the solid state components, including integrated circuits, which comprise the switching, commutation and regulator circuits. Element (B) shows one of the field-coil assemblies, each containing eight bifilar-wound coils. The two sets of coils are offset by 22-1/2°, thus providing a continuously rotating field. Hall-effect devices are located in each layer. The rotor (element C) and platter turn at the selected speed.

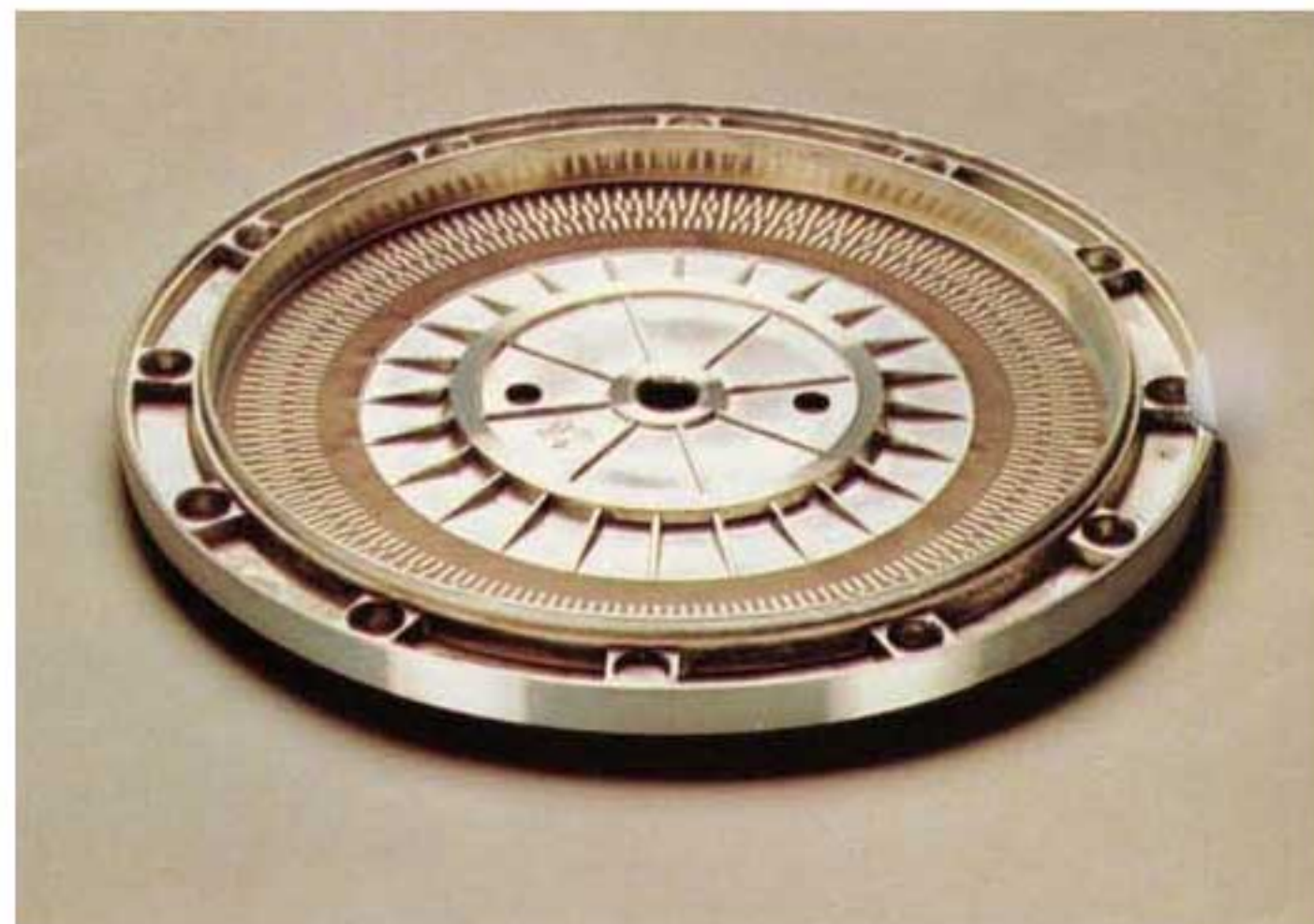

Full-size twelve-inch dynamically balanced, die-cast platter.

The 701 platter rests directly on the rotor and rotates with it at the selected speed. Every platter is cast from a single piece of special zinc alloy which is then individually machined and balanced while rotating at high speed. Any imbalances, however minute, are graphically revealed by computerized gauges and precisely corrected. The platter's full twelve-inch diameter, 9.7 pounds of weight (platter plus rotor) and perfect dynamic balance combine to provide optimum flywheel effect.

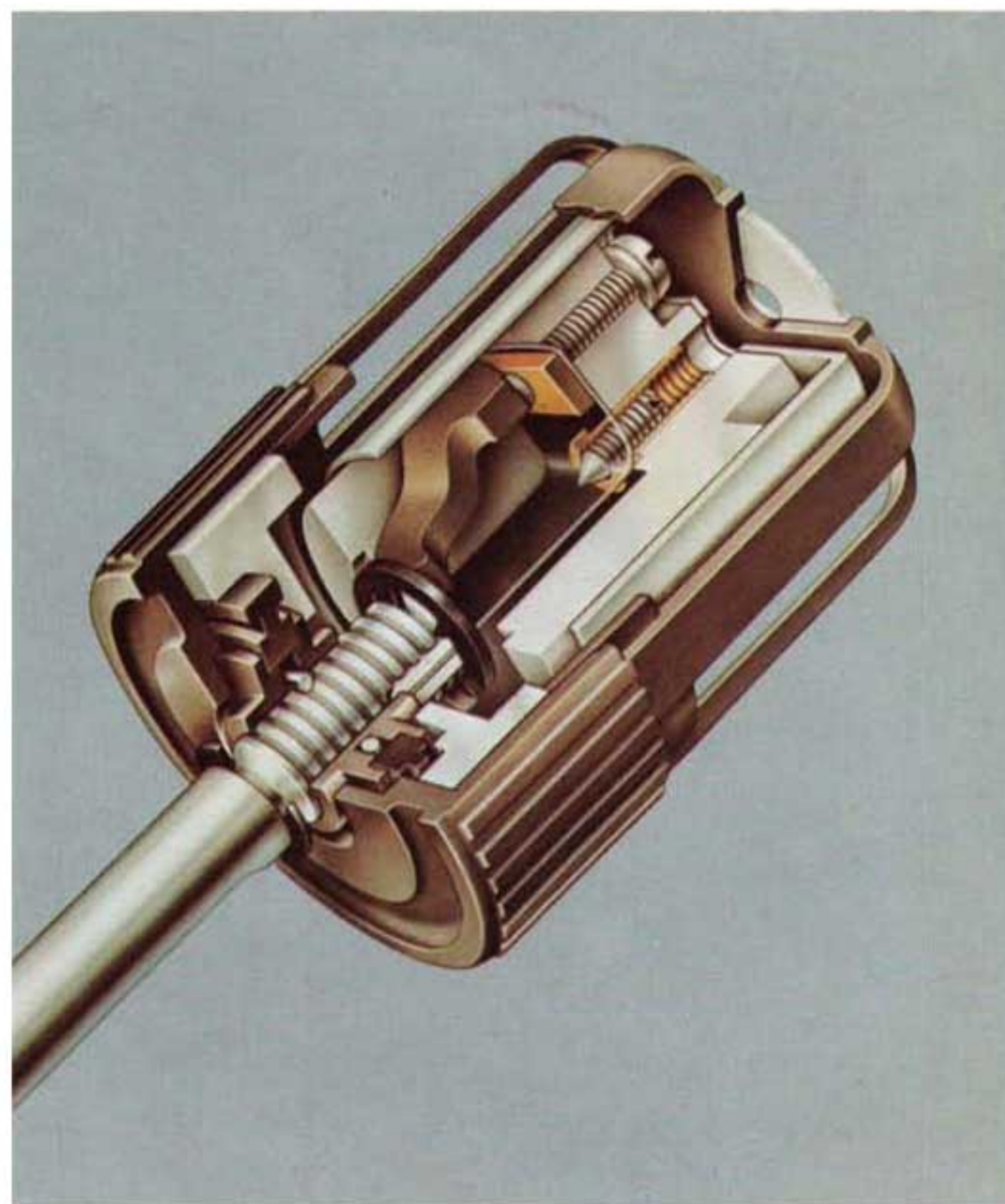

Resonance-cancelling filters integral with counterbalance.

Cutaway view reveals the intricate engineering of the 701's unique counterbalance which houses two separate mechanical filters. These filters absorb resonant energy in the frequency ranges of the tonearm/cartridge system and the chassis. The result is flatter frequency response and greater isolation from acoustical feedback.



Tonearm mounted in four-point low friction gimbal suspension.

The 701 tonearm pivots on identical sets of low-friction needle-point bearings, set in a special designed double gimbal. Each gimbal is hand-assembled and gauges designed by Dual assure that bearing friction will conform to stringent specifications.

Separate anti-skating for conical and elliptical styli.

Balanced tracking pressure on groove sidewalls is assured by separate calibrations for conical and elliptical styli. This provision is required in such low-friction tonearms which are highly responsive to the difference in frictional pull of each stylus shape.

8% pitch-control range for each speed, and built-in illuminated strobe.

An electronic pitch-control, variable over an 8% range, is provided for each of the 701's two speeds (33-1/3 and 45 rpm.) Thus, either speed can be varied without affecting the other setting. Each pitch-control is provided with a reference setting for standardization. For viewing convenience, the illuminated strobe window has an adjustable angle, from directly overhead to approximately 20 degrees forward.



The Dual 701, a model of understated technology.

The 701's appearance is deceptively simple. Since all mechanisms for tonearm settings and speed controls are housed internally, a mere look at the 701 gives little hint of its high degree of sophistication. It does, however, indicate the simplicity of operation. In automatic play, all start and stop functions are controlled by a single switch. In manual play, the turntable is started by simply moving the tonearm toward the record. And in either mode, play may be interrupted any time by lifting the tonearm manually or with the cue control. Moreover, the 701 is designed to maintain original performance standards throughout years of constant use.

The Dual 701 and its state-of-the-art performance.

The Dual 701 is the quietest turntable ever made. Not only in our judgment, but in that of the first independent test laboratory to evaluate its performance. This has been accomplished by an entirely different kind of motor, designed expressly for the 701, and by a very innovative approach to the problem of resonance.

Instead of the familiar, high-speed AC motor, the 701 has an all-electronic, low-speed, DC motor, with feedback-controlled speed precision. Because this motor rotates at the record speed, 33-1/3 or 45 rpm, the need for speed-reduction systems such as friction-idler or rim-belt is eliminated. Instead, the platter is rotated directly by the motor, and the record spindle is the top of the motor shaft.

The 701 motor is so quiet and free from vibration that it does not require any isolation mounting, but is mounted directly to the chassis. Dual's exclusive design of overlapping coils, a unique feature of the motor, eliminates the successive pulses common to every other existing motor, including other electronic types, high speed or low speed.

Another Dual innovation serves to prevent interference from reaching and affecting the stylus. Two separate anti-resonance filters, each tuned to a specific resonance range, are located within the counterbalance housing.

One filter is tuned to the resonant range of the tonearm/cartridge system; the other, to the resonant range of the chassis. Each filter serves to cancel out the resonant energy that would otherwise impart spurious signals to the stylus.

For those who would like to know more about the 701 motor and the anti-resonance filters, a detailed description of both is provided on the back page.

Other features of the 701—the gimbal tonearm suspension, anti-skating and pitch-control—are shown and described on the facing page. Still others include direct-dial tracking pressure, with 0.10 gram calibrations from 0 to 1.5 grams. And, a cue-control, silicone-damped in both directions.

Unlike other Dual turntables, the 701 is designed for only single-play. But like other Duals, it can be operated either fully automatically, or as a manual turntable.

Because of the unique motor and anti-resonance filters, the 701 is slightly quieter than the 1229. But if you now own a 1229, or any other current Dual, you will detect only a minor difference. And we don't suggest that you trade in your present Dual for the 701.

Rather, as an expression of the state of the art, the 701 is recommended for the listener who demands the quietest turntable ever made.

The high level of performance already achieved by Dual turntables raises an appropriate question about the new 701: How does it still further improve the quality of record playback?

Dual turntables have for years been preferred by serious music lovers, including record reviewers and others professionally engaged in high fidelity. Test reports by independent laboratories have repeatedly rated Duals as equalling or surpassing the performance of professional turntables. In addition, knowledgeable readers of the leading high fidelity/equipment magazines continue to purchase more Duals than any other make of quality turntables.

Why then the 701?

The requirements in record playback are far more demanding than those of ten years ago when Dual introduced the 1009, the first record changer to rival the best of the manual turntables. At that time,

no cartridge existed that could track well at under two grams.

Today's best cartridges, of course, can track optimally at below one gram. And typically, an advance in one component requires advances in others. For example, cartridges capable of very low tracking pressure require tonearms with extremely low bearing friction. And since low bearing friction increases the skating effect, highly accurate anti-skating systems are needed to assure equal tracking pressure on both stereo sidewalls.

Most recently, the advent of the four-channel record, with two signal sources on each groove wall, have made tonearm performance even more critical. Two other factors affecting the stylus also have taken on increased importance: motor vibration and tonearm resonance.

It is in these two areas that you will find most of the answers to the question: why the 701?

The motor of the Dual 701.

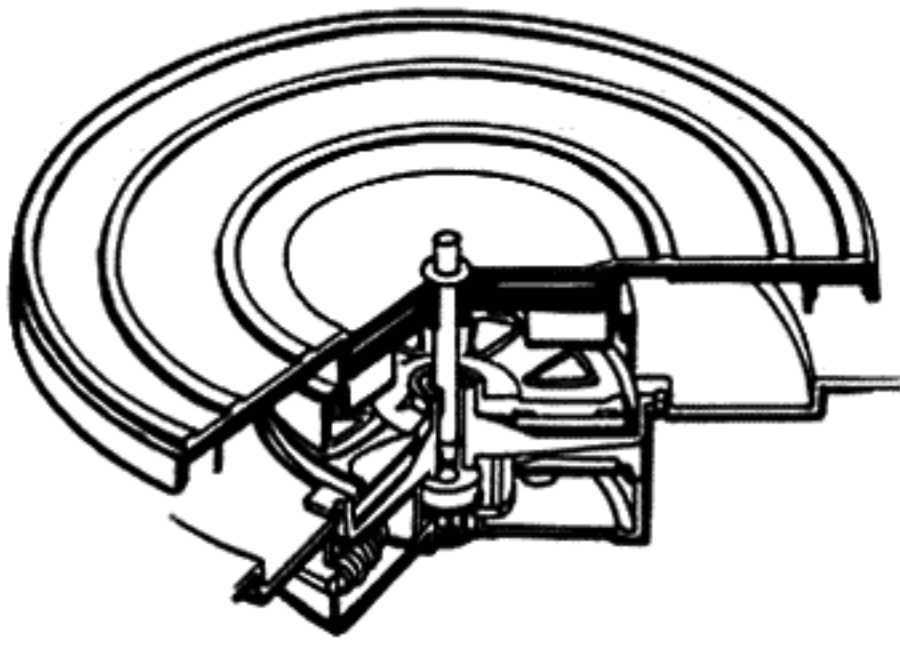

The EDS-1000 motor developed by Dual for the 701 is an all-electronic, low-speed, brushless, DC motor with Hall-effect feedback control, and energized by a regulated power supply.

Unlike conventional DC motors, commutation (electrical switching) is not done by brushes and commutator ring. The 701 motor has electronic switching, commutation and speed regulation. Two Hall-effect generators drive four switching transistors which produce a rotating

magnetic field in the motor's field coils. Depending on the position of the rotor, the magnetic field causes the four magnetic pairs on the rotor to be pushed and pulled continuously.

The field coil design is unique and exclusive with Dual. Two stacked coil layers, each consisting of eight bifilar-wound (coreless) coils, offset by 22.5°, achieving a gapless rotating magnetic field that eliminates the successive pulses of magnetic flux typical of all other motor designs.

Note: The absence of magnetic spring-back or other rotation irregularities can be demonstrated by turning the rotor manually, no resistance will be sensed. Also, because of the coreless field coils the motor is free of hysteresis or eddy-current losses and the disturbances of pole frequencies.

The rotational speed of the 701 motor is controlled electronically. A voltage which is a function of motor speed is fed to an electronic regulating circuit, and is compared to a constant standard voltage

derived from a regulated power supply. Any difference in these two voltages causes an immediate change in the motor current, hence the motor speed.

The rotor is a barium ferrite ring magnet, magnetized in eight segments (poles) on its lower front surface. A steel plate serves as a magnetic return circuit. The regulated power supply makes the speed independent of variations in power-line voltage or frequency. Speed can be set directly to either 33-1/3 or 45 rpm. Thus, the platter is driven directly by the rotor, without need for any speed-reducing linkage such as friction-idler or rim-belt.

Further, in contrast to the high speed (1800 rpm) vibrations of the conventional AC motor, the 701 motor is so free from vibration that it is mounted directly to the chassis without introducing any rumble.

In summary, the 701 electronic direct-drive system, with its over-lapping gapless design, rotating magnetic return circuit and coreless field windings, is the most advanced drive system available for record playback today.

The mechanical anti-resonance filters of the Dual 701.

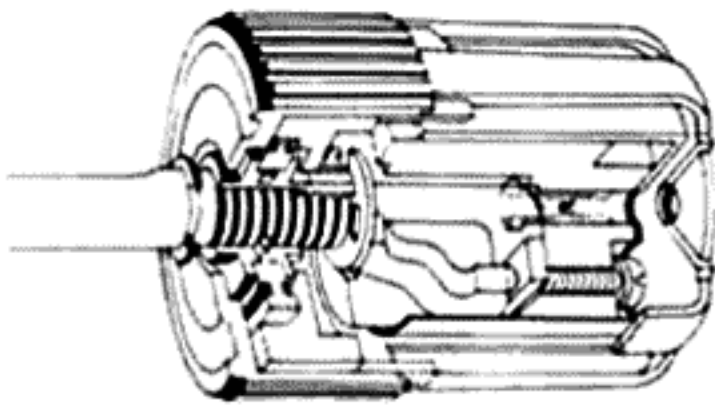

The tonearm's influence on tracking is usually related to balance, tracking pressure and anti-skating. But these static factors do not take into account certain dynamic influences on the stylus during play: Resonance of the tonearm mass and cartridge, and the stylus compliance. Another resonant mass is the turntable chassis, as well as such external sources of mechanical disturbances as record warp, acoustical feedback and room vibration.

When a stylus is resonating from external influences, instead of just the recorded material, its nominally optimum tracking pressure can become momentarily insufficient, with distortion resulting.

Another problem is the eccentricity of every record which tends to unbalance the tracking pressure of the two side walls of the stereo groove, hence their relative output. But the extremely low bearing friction of the 701 tonearm prevents an unequal output from the left and right channels to result.

All these conditions were considered in the development and design of the Dual

701. The solution: two mechanical anti-resonance filters; one tuned to the resonant frequency range of the tonearm/cartridge; the other, to the resonant range of the chassis and other external influences. The filters are located in the housing of the counterbalance.

Tonearm/cartridge system resonance is affected mostly by stylus compliance; to a lesser extent by cartridge weight. Accordingly the resonant frequency of the first filter was designed to accommodate the widest possible range of stylus compliances, from 15 to 50 x 10⁻⁶ cm/dyne.

The filter tuned to the higher resonant frequency of the chassis attenuates resonances that are in the rumble range. The tendency of the tonearm to vibrate has already been largely reduced by the motor's inherent freedom from vibration, but the remaining resonances in the chassis mass must be damped to prevent excitation by acoustical or other mechanical feedback.

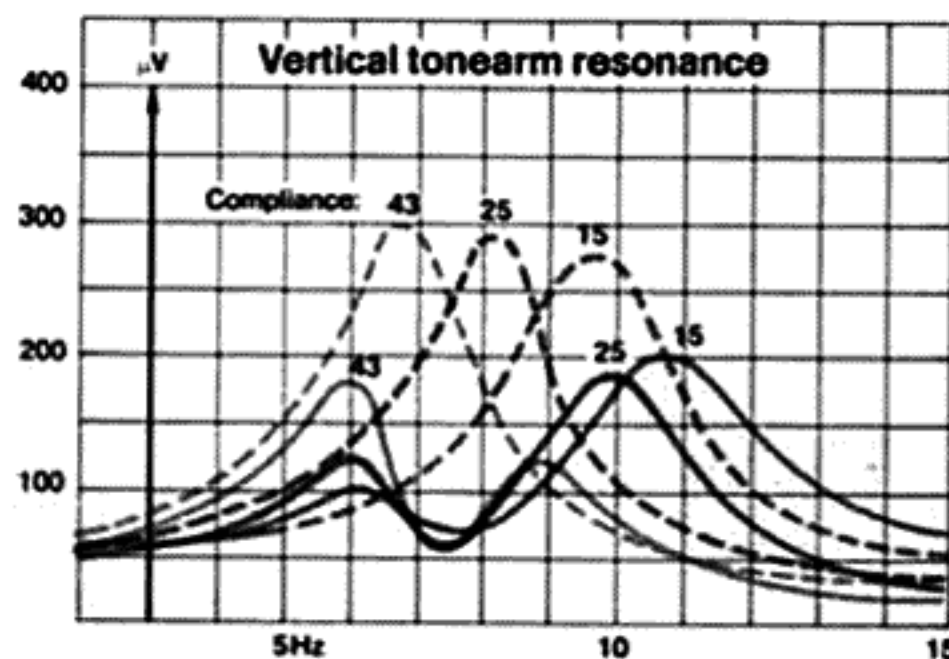

Fig. A. Unbroken lines show effect of tonearm/cartridge anti-resonance filter on

three cartridges, each weighing 4.5 grams; static compliance, 15, 25 and 43 x 10⁻⁶ cm/dyne. The excitation amplitude used in these tests was 50 micrometers. Greatest attenuation occurs at 7.5 Hz. Broken lines show resonant amplitude with non-filtered counterbalance.

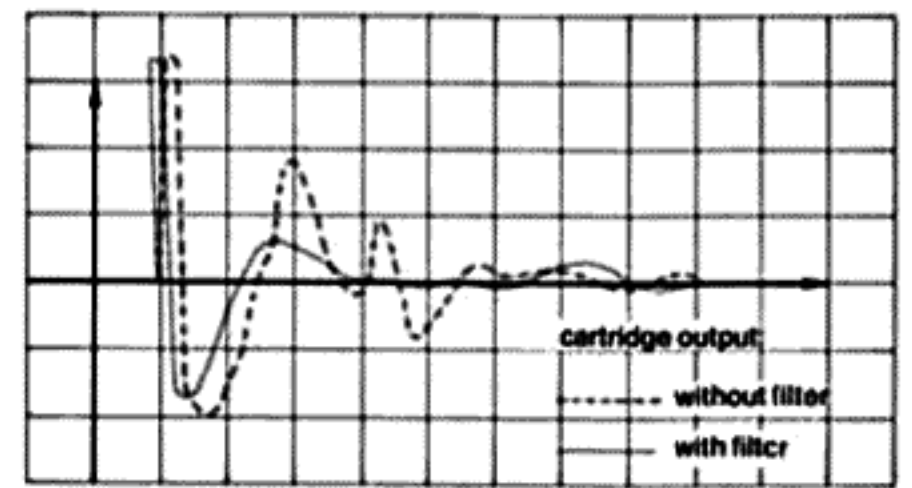

Fig. B. Influence of tonearm/cartridge anti-resonance filter when tonearm is dropped 4mm on grooveless record. Note rapid damping compared with much longer vibration influence without filter.

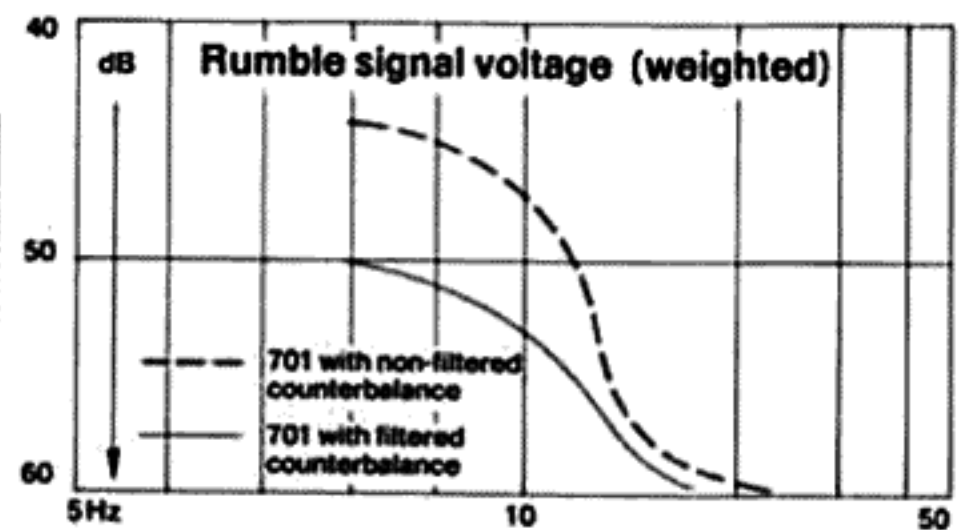

Fig. C. Effect on rumble of chassis anti-resonance filter compared with non-filtered counterbalance.

Dual

United Audio Products, Inc., 120 So. Columbus Ave., Mt. Vernon, N.Y. 10553

Exclusive U.S. Distribution Agency for Dual.